

## 9-Line SCSI Terminator (Reverse Disconnect)

### FEATURES

- Complies with SCSI, SCSI-2, SCSI-3, SPI, and FAST-20 Standards
- 1.8pF Channel Capacitance During Disconnect
- 50 $\mu$ A Supply Current in Disconnect Mode
- 110 $\Omega$  Termination
- SCSI Hot Plugging Compliant, 10nA Typical
- +200mA Sinking Current for Active Negation
- -400mA Sourcing Current for Termination
- Trimmed Impedance to 5%
- Logic Command Disconnect all Termination Lines
- Current Limit and Thermal Shutdown

### DESCRIPTION

The UCC5615 provides 9 lines of active termination for a SCSI (Small Computers Systems Interface) parallel bus. The SCSI standard recommends and Fast-20 (Ultra) requires active termination at both ends of the cable.

Pin for pin compatible with the UC5605 and UCC5606, the UCC5615 is ideal for high performance 5V SCSI systems, Tempwr 4V to 7V. During disconnect the supply current is only 50 $\mu$ A typical, which makes the IC attractive for lower powered systems.

The UCC5615 is designed with a low channel capacitance of 1.8pF, which eliminates effects on signal integrity from disconnected terminators at interim points on the bus.

The power amplifier output stage allows the UCC5615 to source full termination current and sink active negation current when all termination lines are actively negated.

The UCC5615, as with all Unitrode terminators, is completely hot pluggable and appears as high impedance at the terminating channels with TRMPWR=0V or open.

Internal circuit trimming is utilized, first to trim the 110 $\Omega$  impedance, and then most importantly, to trim the output current as close to the maximum SCSI-3 and SPI-2 specification as possible, which maximizes noise margin in FAST-20 SCSI operation.

Other features include thermal shutdown and current limit.

### BLOCK DIAGRAM

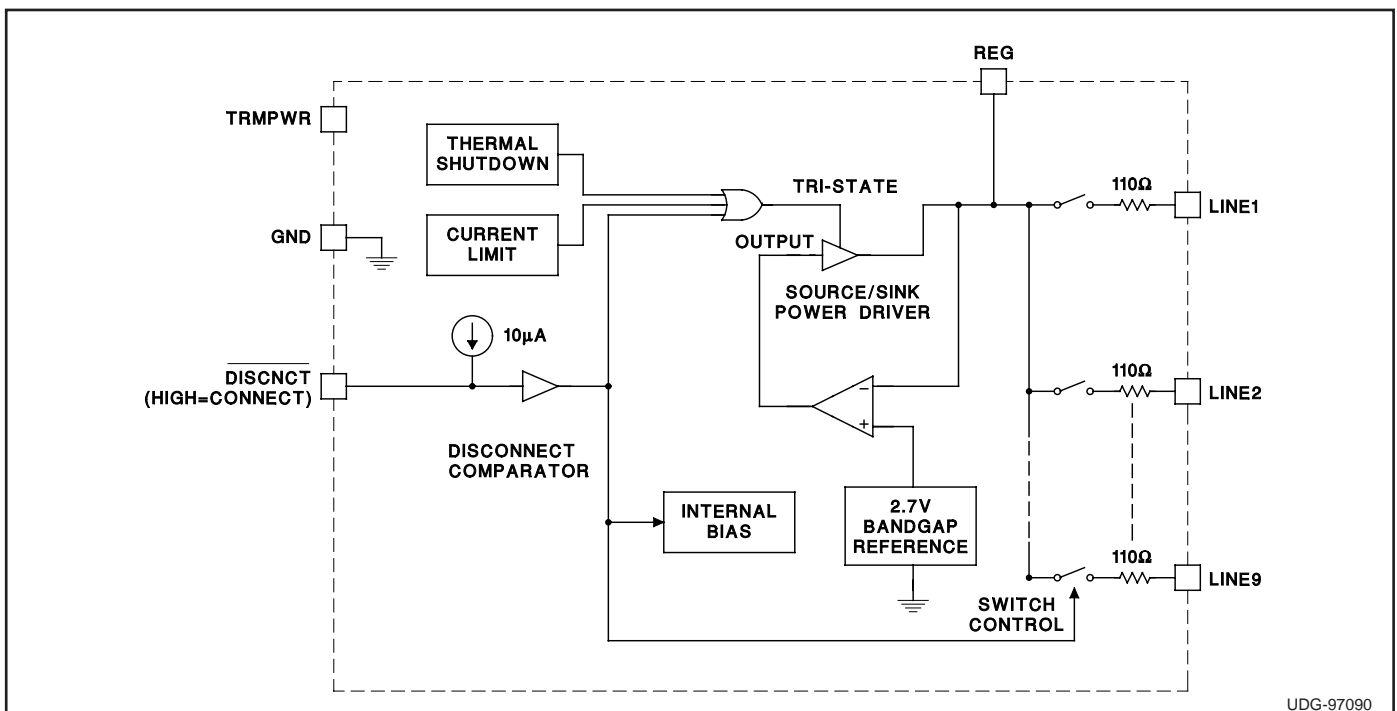

UDG-97090

Circuit Design Patented

**ABSOLUTE MAXIMUM RATINGS**

Tempwr .....+7V  
 Signal Line Voltage .....0V to +7V  
 Regulator Output Current .....0.5A  
 Storage Temperature .....-65°C to +150°C  
 Operating Junction Temperature .....-55°C to +150°C  
 Lead Temperature (Soldering, 10 Seconds) .....300°C

All currents are positive into, negative out of the specified terminal. Consult Packaging Section of Databook for thermal limitations and considerations of packages.

**CONNECTION DIAGRAMS**

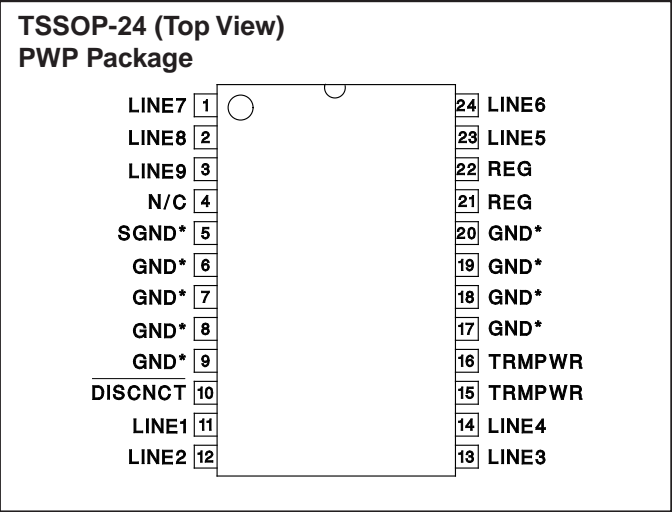

\* PWP package pin 5 serves as signal ground; pins 6, 7, 8, 9, 17, 18, 19, and 20 serve as heatsink ground.

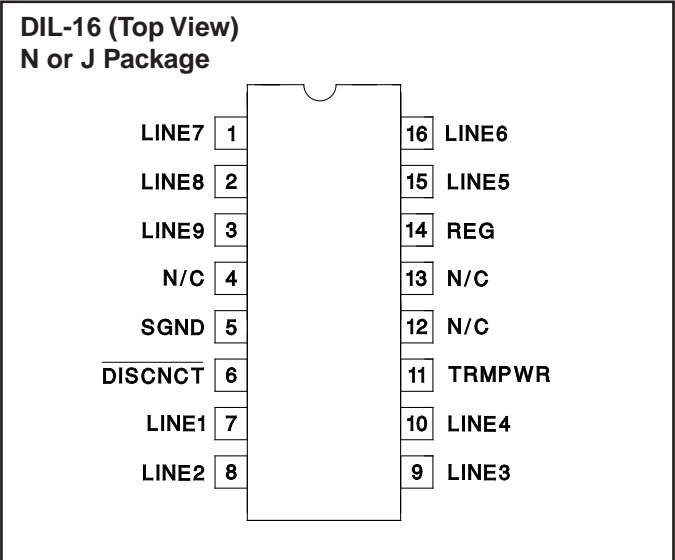

Note: Drawings are not to scale.

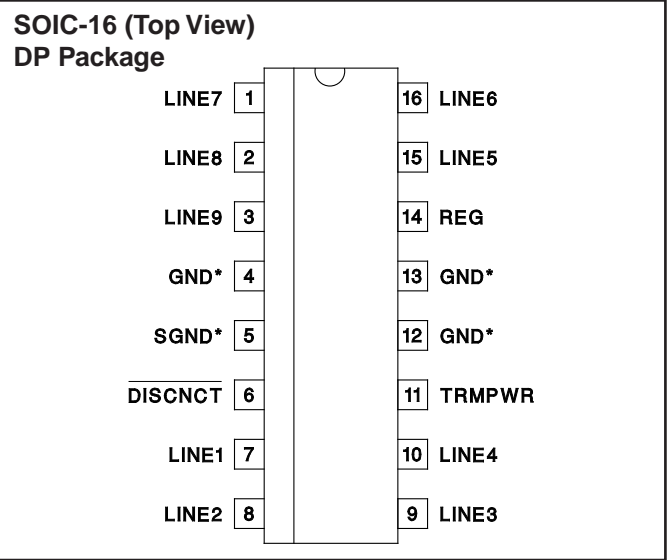

\* DP package pin 5 serves as signal ground; pins 4, 12, and 13 serve as heatsink/ground.

**ELECTRICAL CHARACTERISTICS** Unless otherwise stated these specifications apply for TA = 0°C to 70°C, TRMPWR = 4.75V, DISCNCT = 4.75V, TA = TJ.

PARAMETER	TEST CONDITIONS	MIN	TYP	MAX	UNITS
<b>Supply Current Section</b>					
Tempwr Supply Current	All termination lines = Open		1	2	mA
	All termination lines = 0.2V		210	230	mA
Power Down Mode	DISCNCT = 0V		50	100	µA
<b>Output Section (Termination Lines)</b>					
Termination Impedance	(Note 3)	104.5	110	115.5	Ω
Output High Voltage	VTRMPWR = 4V (Note 1)	2.6	2.8	3	V
Maximum Output Current	VLINE = 0.2V, TJ = 25°C	-22.1	-23.3	-24	mA
	VLINE = 0.2V	-20.7	-23.3	-24	mA
	VLINE = 0.2V, TRMPWR = 4V, TJ = 25°C (Note 1)	-21	-23	-24	mA
	VLINE = 0.2V, TRMPWR = 4V (Note 1)	-20	-23	-24	mA
	VLINE = 0.5V			-22.4	mA

**ELECTRICAL CHARACTERISTICS (cont.)** Unless otherwise stated these specifications apply for  $T_A = 0^\circ\text{C}$  to  $70^\circ\text{C}$ ,  $\text{TRMPWR} = 4.75\text{V}$ ,  $\overline{\text{DISCNCT}} = 4.75\text{V}$ ,  $T_A = T_J$ .

PARAMETER	TEST CONDITIONS	MIN	TYP	MAX	UNITS
<b>Output Section (Termination Lines) (cont.)</b>					
Output Leakage	$\overline{\text{DISCNCT}} = 0\text{V}$ , $\text{TRMPWR} = 0\text{V}$ to $5.25\text{V}$ , $\text{REG} = 0.2\text{V}$		10	400	nA
Output Capacitance	$\overline{\text{DISCNCT}} = 2.4\text{V}$ (Note 2)		1.8	2.5	pF
<b>Regulator Section</b>					
Regulator Output Voltage		2.6	2.8	3	V
Drop Out Voltage	All Termination Lines = $0.2\text{V}$		0.4	0.8	V
Short Circuit Current	$V_{\text{REG}} = 0\text{V}$	-225	-400	-600	mA
Sinking Current Capability	$V_{\text{REG}} = 3.5\text{V}$	100	200	400	mA
Thermal Shutdown			170		$^\circ\text{C}$
Thermal Shutdown Hysteresis			10		$^\circ\text{C}$
<b>Disconnect Section</b>					
Disconnect Threshold		0.8	1.5	2	V
Input Current	$\overline{\text{DISCNCT}} = 0\text{V}$		-10	-30	$\mu\text{A}$

Note 1: Measuring each termination line while other 8 are low ( $0.2\text{V}$ ).  
 Note 2: Guaranteed by design. Not 100% tested in production.  
 Note 3: Tested by measuring  $I_{\text{out}}$  with  $V_{\text{out}} = 0.2\text{V}$  and  $V_{\text{out}}$  with no load, then calculating:

$$Z = \frac{V_{\text{out N.L.}} - 0.2\text{V}}{I_{\text{out at } 0.2\text{V}}}$$

**PIN DESCRIPTIONS**

**$\overline{\text{DISCNCT}}$** : Taking this pin low causes the 9 channels to become high impedance and the chip to go into low-power mode; a high or open state allows the channels to provide normal termination.

**LINE 1-9**:  $110\Omega$  termination channels.  
**REG**: Output of the internal  $2.8\text{V}$  regulator.  
**TRMPWR**: Power for the IC.

**GND**: Ground reference for the IC.

**APPLICATION INFORMATION**

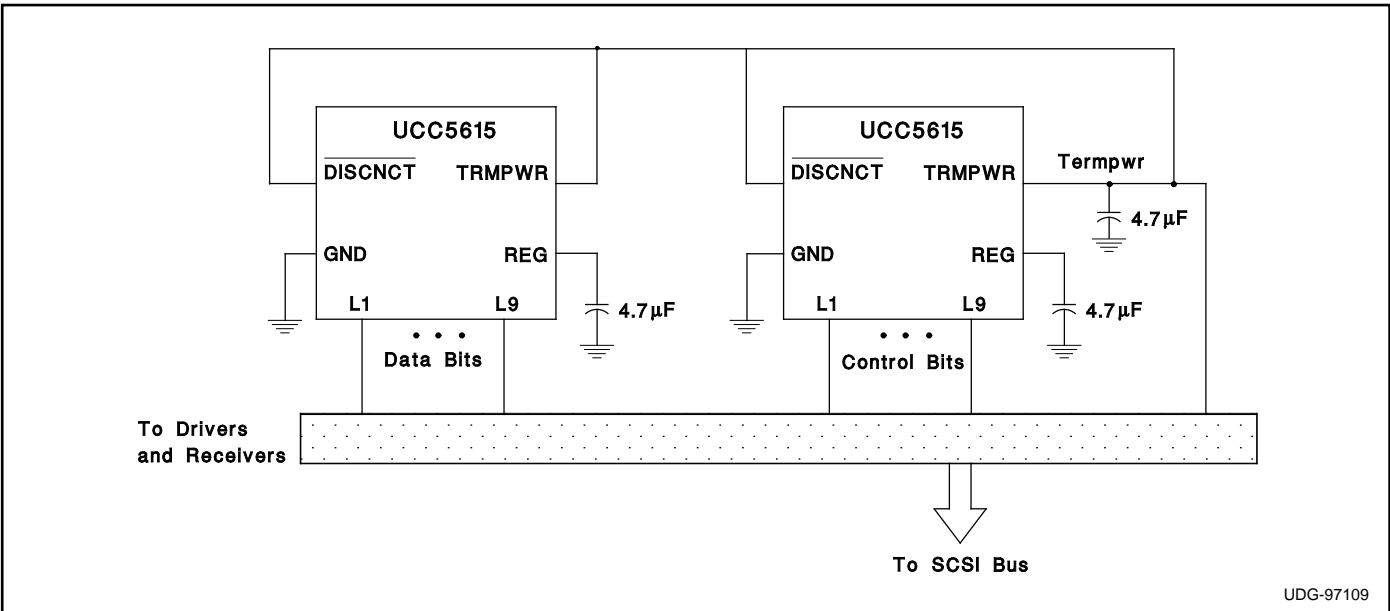

UDG-97109